

FLU-206A Online Fluoride Ion Sensor

User Manual



YANTAI CHEMINS INSTRUMENT CO., LTD.

Tel: 0535-3463801 0571-89870583

E-mail: service@chemins-tech.com service@chemins-env.com

Website: www.chemins-tech.com

Address: No. 15, Entrepreneurship Base, Development Zone, Zhaoyuan City,
Shandong Province

User Notes

- Please read the instructions carefully before using and save it for reference.
- Please follow the instructions and precautions.
- When receiving the instrument, please open the packaging carefully, inspect equipment's damage level in case of transportation, if you found spoiled equipment, please immediately notify the manufacturer and distributor, and retain the packaging, in order to send back to processing.
- When the instrument is in trouble, please don't repair it by yourself, please directly contact the maintenance department of the manufacturer.

Content

User Notes.....	2
I 、 Environment Application.....	4
II 、 Technical performance and specifications.....	4
1. Technical parameters.....	4
2. Dimensional drawing.....	5
III、 Installation and electrical connection.....	5
1. Installation.....	5
2. Electrical connection.....	5
IV、 Maintenance.....	6
1. Use and maintenance.....	6
2. Sensor calibration.....	6
V 、 Quality and service.....	6
1. Quality assurance.....	6
2. Accessories and spare parts.....	7
3. After-sales service commitment.....	7
Appendix data communication.....	8

I 、 Environment Application

FLU-206A integrated on-line fluoride ion sensor uses a solid membrane ion-selective electrode for testing free fluoride ions in water with temperature compensation to ensure fast, simple, accurate and economical testing. The technical parameters, communication protocols, and maintenance of the fluoride ion sensor are described in detail in this manual.

- Signal output: RS-485 bus (Modbus/RTU) protocol, convenient to connect to PLC, DCS, industrial control computer, general controller, paperless recording instrument or touch screen and other third-party equipment.
- The patented fluoride ion probe, the internal reference solution oozes extremely slowly from the microporous salt bridge under the pressure of at least 100KPa (1Bar). Such a reference system is very stable and has a longer electrode life than conventional industrial electrodes.
- Easy to install: 3/4 inch NPT pipe thread for easy submersible installation or installation in pipes and tanks.
- IP68 protection level.

II 、 Technical performance and specifications

1. Technical parameters

Model	FLU-206A
Measuring range	0~100mg/L
Resolution	0.01mg/L
Accuracy	±10% or ±1mg/L, ±0.5°C
Working temp	0~40°C
Working pressure	<0.1MPa
pH range of the medium	5~8 pH
Temperature compensation	Automatic temperature compensation (Pt1000)
Power supply	12~24VDC
Signal output	RS-485 bus, Modbus/RTU protocol
Wetted material	POM
Installation method	3/4"NPT tube thread, immersion mounting
Cable length	5 meters, can be customized
Calibration method	Two-point calibration
Power consumption	0.2W@12V
Protection grade	IP68

2. Dimensional drawing

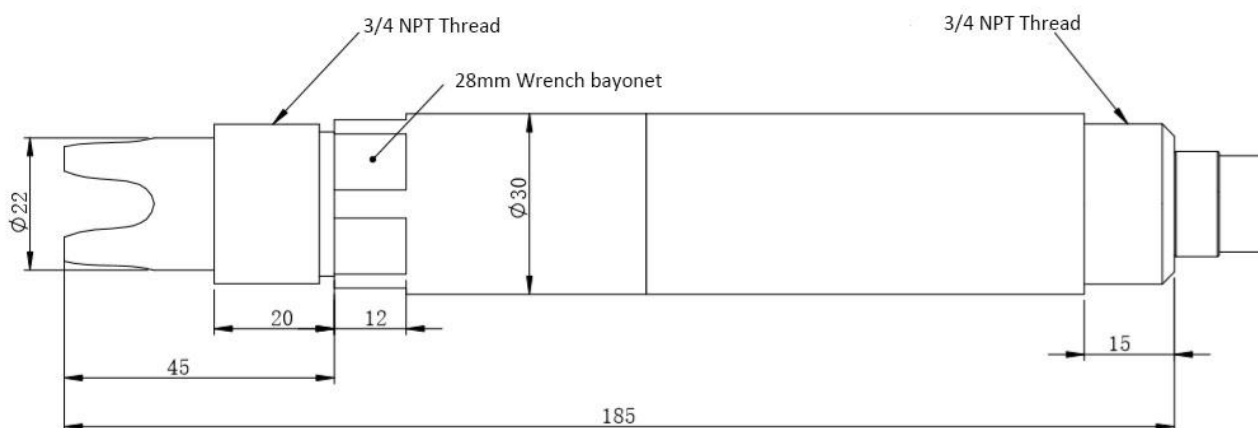

III、 Installation and electrical connection

1. Installation

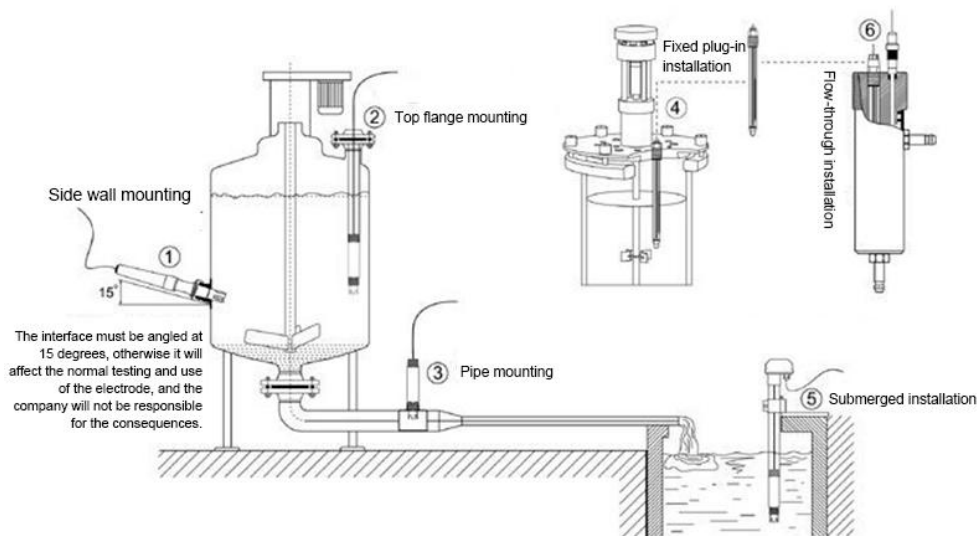

Note: The sensor should not be installed upside down or horizontally when installed, at least at an angle of 15 degrees or more.

2. Electrical connection

- a) Red line - power cord (12 ~ 24VDC)
- b) Black line - ground (GND)
- c) Blue line - 485A

d) White line - 485B

After wiring is completed, it should be carefully checked to avoid incorrect connections before powering up.

Cable specification: Considering that the cable is immersed in water (including sea water) for a long time or exposed to the air, all the wiring points are required to do waterproof treatment, the user cable should have certain corrosion resistance.

IV、 Maintenance

1. Use and maintenance

The fluoride ion electrode was activated in deionized water for 24 hours prior to use.

The sensing element of the fluoride ion electrode must be cleaned with deionized water and kept dry during storage. If the storage time is more than 8 hours, put a protective cap on the film head. The reference solution of the composite electrode is careful not to be evaporated to cause crystallization. Prior to testing, if the electrode storage time is less than one week, 50 mL of TISAB can be soaked in 50 mL of deionized water. If the storage time is more than one week, the electrode should be cleaned, wiped dry, and placed in the original packaging.

Check if the terminal is dry. If it is stained, wipe it with absolute alcohol and dry it. Avoid long-term immersion in distilled water or protein solution and prevent contact with silicone grease. The electrode is used for a long time. When a measurement error occurs, it must be calibrated with the meter.

When the calibration and measurement cannot be performed while maintaining and maintaining the electrode in the above manner, the electrode has failed. Please replace the electrode.

2. Sensor calibration

Note: The sensor has been calibrated before leaving the factory. If it is not beyond the measurement error, it should not be arbitrarily calibrated.

a) Zero calibration

Place the sensor in a vial containing the zero standard solution and wait for 5 minutes. After the value is stable, see if the displayed value is within the error range. If not, perform a zero calibration. Refer to the appendix for calibration instructions.

b) Slope calibration

Place the sensor in a vial containing the standard solution of the slope and wait for 5 minutes. After the value is stable, see if the displayed value is within the error range. If not, the slope calibration is required. Refer to the appendix for calibration instructions.

V、 Quality and service

1. Quality assurance

- The quality inspection department has standardized inspection procedures, advanced and perfect testing equipment and means, and strictly in accordance with the regulations, to do

72-hour aging test and stability test on the product, and not to allow one unqualified product to leave the factory.

- The receiving party directly returns the product batch with a failure rate of 2%, and all the costs incurred are borne by the supplier. The reference standard refers to the product description provided by the supplier.
- Guarantee the quantity of goods and the speed of shipment.

2. Accessories and spare parts

This product includes:

- 1 sensor
- 1 copy of the manual
- 1 certificate

3. After-sales service commitment

The company provides local after-sales service within one year from the date of sale, but does not include damage caused by improper use. If repair or adjustment is required, please return it, but the shipping cost must be concealed. Damaged on the way, the company will repair the damage of the instrument for free.

Appendix data communication

1. Data format

The default data format for Modbus communication is: 9600, n, 8, 1 (baud rate 9600bps, 1 start bit, 8 data bits, no parity, 1 stop bit).

Parameters such as baud rate can be customized.

2. Information frame format

a) Read data instruction frame

06	03	xx xx	xx xx	xx xx
Address	Function code	Register address	Number of registers	CRC check code (low byte first)

b) Read data response frame

06	03	xx	xx.....xx	xx xx
Address	Function code	Bytes	Answer data	CRC check code (low byte first)

c) Write data instruction frame

06	06	xx xx	xx xx	xx xx
Address	Function code	Register address	Write data	CRC check code(low byte first)

d) Write data response frame (same data command frame)

06	06	xx xx	xx xx	xx xx
Address	Function code	Register address	Write data	CRC check code (low byte first)

3. Register address

Register address	Name	Instruction	Number of registers	Access method
40001 (0x0000)	Fluoride ion measurement+ temperature	4 double-byte integers, which are fluoride ion measurement values, measured value decimal places, temperature values, and temperature value decimal places.	4 (8 bytes)	Read
		Calibrated in a 1 mg/L standard, the data		

44097 (0x1000)	Zero calibration	written is the value of the standard solution concentration x100 used. The read data is the mV value x100 corresponding to the zero point calibration value.	1 (2 bytes)	Write
44101 (0x1004)	Slope calibration	Calibrated in a 10 mg/L standard, the data written is the value of the standard solution concentration x100 used. The read data is the mV value x100 corresponding to the slope calibration value.	1 (2 bytes)	Write
44113 (0x1010)	Temperature value	In solution calibration, write data to the actual temperature x10; Read data for temperature calibration offset x10.	1 (2 bytes)	Write/Read
48195 (0x2002)	Sensor address	Default address is 6, data range is 1-127.	1 (2 bytes)	Write/Read
48225 (0x2020)	Reset sensor	The calibration value is restored to the default value, and the written data is 0. Note that the sensor must be calibrated again after reset before use.	1 (2 bytes)	Write

4. Command example

a) Read the data instruction:

Function: Obtain the fluoride ion solubility value and temperature of the measuring sensor; the unit of fluoride ion is mg/L; the unit of temperature is °C.

Request frame: 06 03 00 00 00 04 45 BE

Response frame: 06 03 08 00 55 00 02 01 18 00 01 B3 5D

Example of reading:

Fluoride ion concentration value

Fluoride ion concentration value	Temperature value
00 55 00 02	01 18 00 01

Such as: fluoride ion value: 00 55 means hexadecimal reading fluoride ion concentration value, 00 02 means fluoride ion concentration value with two decimal places, converted to decimal value of 0.85.

Temperature value: 01 18 indicates the hexadecimal reading temperature value, 00 01 indicates that the temperature value has a decimal number and is converted to a decimal value of 28.0.

b) Calibration instructions:

Zero calibration

Function: Set the fluoride ion zero calibration value of the sensor. Calibrated in a 1 mg/L standard, examples are as follows:

Request frame: 06 06 10 00 00 64 8D 56

Response frame: 06 06 10 00 00 64 8D 56

Slope calibration

Role: Set the sensor's fluoride ion slope calibration value. Calibrated in a 10 mg/L standard, examples are as follows:

Request frame: 06 06 10 04 03 E8 CD C2

Response frame: 06 06 10 04 03 E8 CD C2

c) Set the sensor ID address

Function: Set the sensor's Modbus device address.

Change the device address 06 to 01. The example is as follows

Request frame: 06 06 20 02 00 01 E3 BD

Response frame: 06 06 20 02 00 01 E3 BD

5. Error respond

If the sensor does not correctly execute the host command, it will return the following format information:

Definition	Address	Function code	Code	CRC check
Data	ADDR	COM+80H	xx	CRC 16
Number of bytes	1	1	1	2

- a) CODE: 01 –Function code error
03 – Data is wrong
- b) COM: The received function code