

COD-302 Online COD Sensor User Manual



YANTAI CHEMINS INSTRUMENT CO., LTD

Phone: 0535-3463801 0571-89870583

E-mail: service@chemins-tech.com Website: www.chemins-tech.com

Address: No. 15 Entrepreneurship Base, Zhaoyuan Development Zone,
Shandong Province

User notes

- Please read this manual carefully before use and save it for reference.
- Please follow the operating procedures and precautions in this manual.
- When receiving the instrument, please carefully open the package and check whether the instrument and accessories are damaged due to shipping. If any damage is found, please inform the manufacturer and distributor immediately, and keep the package for return.
- When the instrument fails, do not repair it yourself. Please contact the maintenance department of the manufacturer directly.

Content

I 、	Working principle.....	4
II 、	Technical performance and specifications.....	5
1.	Technical parameters.....	5
2.	Dimensional drawing.....	5
III、	Installation and electrical connection.....	6
1.	Installation.....	6
2.	Electrical connection.....	6
IV、	Maintenance and maintenance.....	7
1.	Maintenance schedule and method.....	7
2.	Sensor calibration.....	8
3.	Precautions.....	9
4.	Common problems and countermeasures.....	9
V 、	Quality and service.....	10
1.	Quality assurance.....	10
2.	Accessories and spare parts.....	10
3.	After-sales service commitment.....	10
	Appendix data communication.....	10

I 、 Working principle

Many organic compounds dissolved in water are absorbent to ultraviolet light. Therefore, the amount of dissolved organic pollutants in the water can be accurately measured by measuring the extent to which these organics absorb UV light at 254nm. The COD-302 online COD sensor adopts two light sources, one is ultraviolet light for measuring COD content in water and the other is reference light for measuring turbidity in water. In addition, the optical path attenuation is compensated by a specific algorithm and the interference of particulate suspended matter can be eliminated to a certain extent, so as to achieve more stable and reliable measurement.



Product features:

- No reagents, no pollution, more economical and environmental protection
- Small size, easy installation, and continuous water quality monitoring
- Measure COD, turbidity and temperature parameters
- Automatic compensation for turbidity interference
- With a cleaning brush to prevent bio-adhesion
- Small drift, fast response, more accurate measurement
- Excellent stability even for long-term monitoring
- Maintenance-free, long service life and low cost of use
- Digital sensor, RS-485 interface, Modbus/RTU protocol
- Low power design, anti-interference design

II 、 Technical performance and specifications

1. Technical parameters

Model	COD-302	
Measuring principle	Dual wavelength ultraviolet absorption method	
Scale range	COD	Turbidity
	0~200mg/L equiv. KHP	0~100NTU
	0~500mg/L equiv. KHP	0~200NTU
COD Precision	±5%F.S.	
COD Resolution	0.1mg/L	
Turbidity accuracy	±5%F.S.	
Turbidity resolution	0.1NTU	
Calibration method	Two-point calibration	
Output method	RS-485 (Modbus/RTU)	
Power supply	12~24VDC	
Power consumption	0.3W@12V	
Working conditions	0~45℃、 <0.1MPa	
Storage temperature	-5~65℃	
Protection level	IP68	
Installation method	Immersion installation	
Cable length	5 meters, other lengths can be customized	
Sensor housing material	316L stainless steel	

2. Dimensional drawing

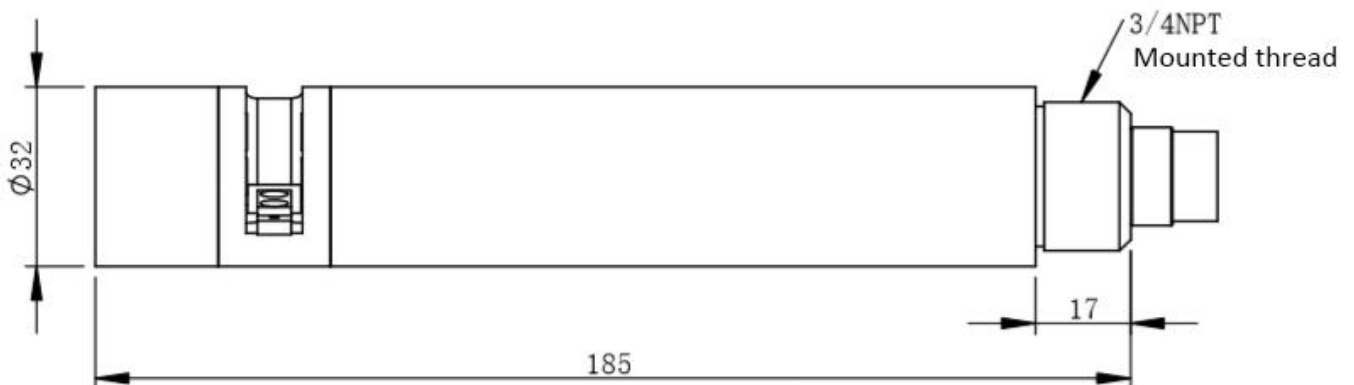

Note: The sensor connector is a male M16-5 core waterproof connector

III、 Installation and electrical connection

1. Installation

When the sensor is attached, the sensor caused by water flow should be prevented from hitting the wall or other water conservancy facilities. If the water flow is very urgent, fix the sensor.

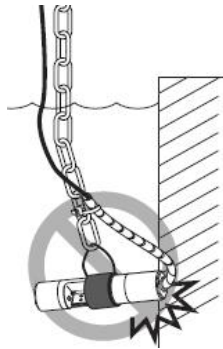

Install the sensor to a depth of no more than 2 meters from the water surface.

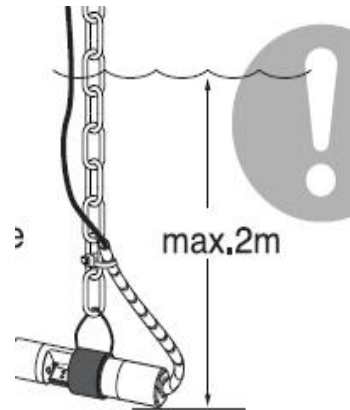

Taking into account the fluctuation of the water level, the sensor is immersed in the lowest possible water level below 30 cm.

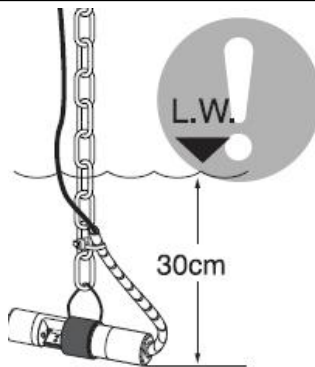

The sensor is placed in a position where there are no bubbles in the water.



Note: It is recommended to install a cable protective cover on the outside of the sensor cable. The sensor can be placed in any direction in the water. It is recommended that the sensor be placed horizontally and firmly fixed, and the measuring area should face the direction of the water flow.

2. Electrical connection

The cable is a 4-core twisted-pair shielded wire, and the line sequence is defined:

- Red line—power cable (12-24VDC)
- Black line—Ground wire (GND)

- Blue line—485A
- White line—485B

After the wiring is completed, it should be carefully checked to avoid the wrong connection before the power is turned on.

Cable specification: considering that the cable is immersed in water (including sea water) or exposed to air for a long time, the cable has a certain corrosion resistance. All interfaces of cable outer diameter $\Phi 6\text{mm}$, have been waterproof.

IV、 Maintenance and maintenance

1. Maintenance schedule and method

1.1 Maintenance schedule

To ensure accurate measurements, cleaning is important, and regular sensor cleaning helps data stability.

Maintenance task	Recommended maintenance frequency
Calibrate the sensor (if required by the competent authority)	According to the maintenance schedule required by the competent authority
Maintain and check the self-cleaning brush	Return to the factory every 18 months for inspection and maintenance of self-cleaning brush

Note: The maintenance frequency in the above table is only a recommendation. Please maintain the sensor according to the actual usage of the sensor.

1.2 Maintenance method

- 1) Sensor outer surface: Clean the outer surface of the sensor with tap water. If there is still debris left, wipe it with a soft, damp cloth. For some stubborn dirt, add some household washing liquid to the tap water to clean it.
- 2) Check the cable of the sensor: the cable should not be tightened during normal operation. Otherwise, the cable inside the cable may be broken, causing the sensor to malfunction.
- 3) Check if the sensor's measurement window is dirty and the cleaning brush is normal.
- 4) Check the sensor's cleaning brush for damage.
- 5) For 18 months of continuous use, it is necessary to return to the factory to replace the dynamic sealing device.

1.3 Precautions

The probe contains sensitive optical and electronic components. Make sure the probe is not subject to severe mechanical shock. There are no parts inside the probe that require user maintenance.

2. Sensor calibration

2.1 Turbidity calibration:

1) Zero calibration: Take a small amount of turbidity liquid from a large beaker and place the sensor vertically in the solution. After 3 to 5 minutes, the value is stabilized and then zero calibration. The instructions refer to the appendix.

2) Slope calibration: Place the sensor in a solution and place it in a 100 NTU standard solution. After 3 to 5 minutes, the slope is calibrated after the value is stabilized. The instructions refer to the appendix.

2.2 COD calibration:

1) KHP(Potassium hydrogen phthalate , $C_8H_5KO_4$) , As a commonly used stain for environmental research, it can be used for COD calibration.

2) Preparation of standard solution

a) Accurately weigh 0.8503 g of KHP into a 1000 mL flask. Distilled or deionized water and perfused until the highest scale. This solution is a 1000 mg / L COD solution.

b) Take 100 mL of this solution into a 1000 mL flask and fill it to the highest mark with distilled or deionized water. After shaking, the COD concentration was 100 mg/L. A solution having a concentration of 20 mg/L was prepared in the same manner.

c) The concentrated standard solution (step 2.1) was stored in a black glass vial and stored at low temperature to prevent decomposition. The diluted standard (step 2.2) needs to be used within 24 hours of preparation.

2.3 Calibration (2-point calibration)

1) 0~200mg/L calibration

A. Place the sensor in a 5mg/L COD solution and verify that all light paths are submerged under water >2cm with no air bubbles. Perform a zero calibration according to the appendix command.

B. Place the sensor in a 200mg/L COD solution and slope calibrate according to the appendix command.

2) 0~500mg/L calibration

A: Place the sensor in a 20mg/L COD solution and verify that all light paths are submerged under water ≥ 2 cm with no air bubbles. Perform a zero calibration according to the appendix command.

B. Place the sensor in a 400mg/L COD solution and slope calibrate according to the appendix command.

Warning:

- **KHP have cancer risk and should be worn with gloves.**
- **When calibrating, firstly calibrate the temperature, then calibrate the turbidity and then calibrate the COD.**
- **If the slope is calibrated, the sensor value does not change within 3 minutes, re-supply after power is cut off.**

3. Precautions

- Avoid the sun exposure of the sensor
- Please do not touch the sensor by hand
- Avoid contact with the sensor surface during measurement and calibration
- Avoid using any mechanical stress (pressure, scratches, etc.) directly on the sensor during use.

4. Common problems and countermeasures

Problem	Possible reason	Solution
The operation interface cannot be connected Or do not display measurement results	Controller and cable connection error	Reconnect controller and cable
	Cable failure	Please contact us
The measured value is too high, too low or the value is continuously unstable	The sensor window is attached by a foreign object	Cleaning the sensor window surface
	Sensor self-cleaning damage	Replace the cleaning brush

V、Quality and service

1. Quality assurance

- The quality inspection department has standardized inspection procedures, advanced and perfect testing equipment and means, and strictly in accordance with the regulations, 72 hours of aging experiments and stability tests on the products, and does not allow a substandard product to leave the factory.

- The receiving party directly returns the batch of products with a non-conformity rate of 2%, and all the costs incurred are borne by the supplier. The reference standard refers to the product description provided by the supplier.

- Guarantee the quantity of goods and the speed of shipment.

2. Accessories and spare parts

This product includes:

- 1 Sensor
- 1 Instruction manual
- 1 Certificate

3. After-sales service commitment

The company provides local after-sales service within one year from the date of sale, but does not include damage caused by improper use. If repair or adjustment is required, please return it, but the shipping cost must be concealed. Damaged on the way, the company will repair the damage of the instrument for free.

Appendix data communication

1. Data format

Modbus communication default data format: 9600, n, 8,1 (baud rate 9600bps, 1 start bit, 8 data bits, no parity, 1 stop bit).

The baud rate can be customized.

2. Information frame format

a)Data read instruction

06	03	xx xx	xx xx	xx xx
Device	Function code	Register address	Register count	CRC code (low byte first)

b)Data read response

06	03	xx	xx.....xx	xx xx
Device	Function code	Data bytes count	Data bytes	CRC code (low byte first)

c)Data write instruction

06	06	xx xx	xx xx	xx xx
Device	Function code	Register address	Data to write	CRC code (low byte first)

d)Data write response(same with data write instruction)

06	06	xx xx	xx xx	xx xx
Device	Function code	Register address	Data to write	CRC code (low byte first)

3. Register address

Register address	Name	Instruction	Number of registers	Access method
0x0000	COD measured value	2 double-byte integers for the measured value and the measured decimal number (default is 1 decimal).	2 (4 bytes)	Read(0x03)
0x0002	Temperature measured value	2 double-byte integers, the temperature value and the temperature value decimal number (the default is 1 decimal).	2 (4 bytes)	Read(0x03)
0x0004	Turbidity measured value	Two double-byte integers for the measured value and the measured decimal number (default is 1 decimal).	2 (4 bytes)	Read(0x03)
0x1000	COD zero calibration	Calibration was performed in deionized water.The calibration value data written during calibration is 0;The data read	1 (2 byte)	write(0x06)/ Read(0x03)

		<p>out is the original SIGNAL of COD zero.(The range of 0-200mg/L can also be calibrated in 0-20mg/L COD standard liquid. The calibration value data written during the calibration is the value of the standard liquid concentration x10;The range of 0-500mg/L can also be calibrated in 0-50mg/L COD standard liquid. The calibration value data written during the calibration is the value of the standard liquid concentration x10.)</p>		
0x1004	COD slope calibration	<p>The range of 0-200mg/L is calibrated in a standard liquid of 20-200mg/L.The calibration value data written during calibration is the value of the standard liquid concentration x10.The data read out is the original signal of COD slope;The range of 0-500mg/L is calibrated in a standard fluid of 50-500mg/L.The calibration value data written during calibration is the value of the standard liquid concentration x10.The data read out is the original signal of COD slope.</p>	1 (2 byte)	write(0x06)/ Read(0x03)
0x1010	Temperature calibration	<p>In solution calibration, write data to the actual temperature x10; Read data for temperature calibration offset</p>	1 (2 byte)	Read(0x03)/w rite(0x06)

		x10.		
0x1020	Turbidity zero alignment	Calibrate in zero turbidity water. The calibration value data written during calibration is 0; The read data is a zero offset.	1 (2 byte)	Read(0x03)/write(0x06)
0x1024	Turbidity slope calibration	It can be calibrated in a standard solution of 20-100ntu. The calibration value data written during calibration is the value of the standard liquid concentration x10; The data read out is the slope value x1000.	1 (2 byte)	Read(0x03)/write(0x06)
0x1100	Sensing switch	Turn sensor measurement on or off. Turn off the measurement when the written data is 0; Open the measurement when writing data to 1. The sensor is powered on by default.	1 (2 byte)	Write(0x06)
0x2002	Sensor address	Default is 6. Write data range 1-127.	1 (2 byte)	Write(0x06)/read(0x03)
0x1300	Automatic cleaning interval setting	The default is 30 minutes. Data range from 6 to 6000 minutes.	1 (2 byte)	Write(0x06)
0x1301	Automatic cleaning turn number setting	The default is 3 laps. Data range 0 ~ 6 laps.	1 (2 byte)	Write(0x06)/read(0x03)
0x2020	Reset sensor	The calibration value restores the default value and writes to 0. Note that the sensor should be recalibrated after reset before use.	1 (2 byte)	Write(0x06)

4. Command example

a) Measurement instruction::

Function: Read the COD and temperature values of the sensor;The unit of COD is mg/L and the unit of temperature is °C.

Request frame: 06 03 00 00 00 04 45 BE

Response frame: 06 03 08 03 62 00 01 00 B9 00 01 E5 95

Reading sample:

COD value	Temperature value
03 62 00 01	00 B9 00 01

For example : COD value 03 62 represents hexadecimal reading COD value, 00 01 represents COD with 1 decimal point, converted to decimal value is 86.6.

The temperature value 00 B9 represents the hexadecimal reading value and 00 01 represents the temperature value with one decimal point, which translates to 18.5°C.

b) Calibration instructions:

- Temperature calibration

Function: Calibrate sensor temperature 25.8 °C;Temperature calibration shall be performed after a period of temperature stabilization:

Request frame: 06 06 10 10 01 02 0D 29

Response frame: 06 06 10 10 01 02 0D 29

- Turbidity zero calibration

Function: Set the turbidimetric zero calibration value of the sensor;Zero calibration is performed in zero turbidity water:

Request frame: : 06 06 10 20 00 00 8D 77

Response frame: 06 06 10 20 00 00 8D 77

- Turbidity slope calibration

Function: Set the calibration value of turbidity slope of the sensor;Command to calibrate slope in 100NTU solution:

Request frame: 06 06 10 24 03 E8 CC 08

Response frame: 06 06 10 24 03 E8 CC 08

- COD zero calibration(take 0-500mg/L range as an example)

Function: Set the COD zero calibration value of the sensor;Command at zero calibration in 5mg/L solution:

Request frame: 06 06 10 00 00 C8 8D 2B

Response frame: 06 06 10 00 00 C8 8D 2B

COD slope calibration(take 0-500mg/L range as an example)

Function: Set the COD slope calibration value of the sensor;Command to calibrate slope in 100mg/L solution:

Request frame: 06 06 10 04 0F A0 C8 F4

Response frame: 06 06 10 04 0F A0 C8 F4

c) Boot instruction:

Function: Turn on or off the sensor measurement function.Note that the default is power on.

Request frame: 06 06 11 00 00 01 4C 81

Response frame: 06 06 11 00 00 01 4C 81

d) Change the device ID address:

Function: Change the Modbus device address of the sensor.

Change the sensor address from 06 to 01, for example:

Request frame: 06 06 20 02 00 01 E3 BD

Response frame: 06 06 20 02 00 01 E3 BD

5. Error response

If the sensor does not execute the host computer correctly, it will return the following format information:

Definition	Address	Function code	Code	CRC check
Data	ADDR	COM+80H	xx	CRC 16
Number of bytes	1	1	1	2

a) CODE: 01 - functional code error

03 - Data error

b) COM: received function code